

CONSTRUCTUS

Requirements for Tice River Homes

John Ford, Lukas Blakk, Nino D'Aversa, Jesse Valianes

8/21/2007

This document outlines the scope and features of Constructus, a system designed to enable Tice River Homes to automate the tracking of their home building projects.

Table of Contents

<u>Table of Figures.....</u>	<u>4</u>
<u>Introduction.....</u>	<u>5</u>
<u>Scope.....</u>	<u>5</u>
<u>Features.....</u>	<u>5</u>
<u>Contractor Management Module.....</u>	<u>5</u>
<u>Contract Management Module.....</u>	<u>5</u>
<u>Lot Management Module.....</u>	<u>5</u>
<u>Report Generation Module.....</u>	<u>6</u>
<u>Work Order Management Module.....</u>	<u>6</u>
<u>Completion Management Module.....</u>	<u>6</u>
<u>Email Notification.....</u>	<u>6</u>
<u>Backup of Virtual Machines.....</u>	<u>6</u>
<u>Operating Environment.....</u>	<u>6</u>
<u>Use Case Diagram.....</u>	<u>7</u>
<u>Scenarios and System Sequence Diagrams.....</u>	<u>8</u>
<u>HD Create Contractor.....</u>	<u>8</u>
<u>HD Update Contractor.....</u>	<u>9</u>
<u>HD Delete Contractor.....</u>	<u>10</u>
<u>HD Backup Virtual Machines.....</u>	<u>11</u>
<u>HD Create Lot Status Report.....</u>	<u>12</u>
<u>HD Create Lots Closing Report.....</u>	<u>13</u>
<u>HD Create Daily Superintendent Schedule.....</u>	<u>15</u>
<u>HD Create Completion Report.....</u>	<u>16</u>
<u>HD Create WorkOrder Report.....</u>	<u>18</u>
<u>HD Export to PDF.....</u>	<u>19</u>
<u>HD Create Contract.....</u>	<u>20</u>
<u>HD Update Contract, change lot number.....</u>	<u>22</u>
<u>HD Delete Contract.....</u>	<u>23</u>

Constructus
August 21, 2007

<u>HD Create Lot.....</u>	<u>25</u>
<u>HD Update Lot, add special note.....</u>	<u>26</u>
<u>HD Delete Lot.....</u>	<u>28</u>
<u>HD Create WorkOrder.....</u>	<u>29</u>
<u>HD Modify Work Order.....</u>	<u>31</u>
<u>HD Archive Work Order.....</u>	<u>32</u>
<u>HD Retrieve Work Order.....</u>	<u>33</u>
<u>HD Email Notification – 24hour.....</u>	<u>35</u>
<u>HD Create Completion.....</u>	<u>35</u>
<u>HD Close Completion.....</u>	<u>36</u>
<u>HD Modify Completion.....</u>	<u>38</u>
<u>Stakeholders.....</u>	<u>39</u>
<u>Business Rules.....</u>	<u>39</u>
<u>Implementation Plan for Use Cases.....</u>	<u>39</u>
<u>Appendix A: Log of meetings with client.....</u>	<u>41</u>
<u>Log of meetings with Ray.....</u>	<u>42</u>
<u>Appendix B: Screen and Report Templates.....</u>	<u>43</u>
<u>Screens.....</u>	<u>44</u>
<u>Main Menu.....</u>	<u>44</u>
<u>User Interface Template.....</u>	<u>45</u>
<u>Reports.....</u>	<u>46</u>
<u>Lot Status Report.....</u>	<u>46</u>
<u>Lot Closing Report.....</u>	<u>47</u>
<u>Daily Superintendant Schedule.....</u>	<u>48</u>
<u>Completion Report.....</u>	<u>49</u>
<u>Work Order Report.....</u>	<u>49</u>
<u>Appendix C: Signed Contract.....</u>	<u>50</u>

Table of Figures

Figure 1 - Use Case Diagram.....	7
Figure 2 - HD Create Contractor.....	9
Figure 3 - HD Update Contractor.....	10
Figure 4 - HD Delete Contractor.....	11
Figure 5 - HD Backup Virtual Machines.....	12
Figure 6 - HD Create Lot Status Report.....	13
Figure 7 - HD Create Lots Closing Report.....	14
Figure 8 - HD Create Daily Superintendent Schedule.....	16
Figure 9 - HD Create Completion Report.....	17
Figure 10 - HD Create WorkOrder Report.....	19
Figure 11 - HD Export to PDF.....	20
Figure 12 - HD Create Contract.....	21
Figure 13 - HD Update Contract.....	23
Figure 14 - HD Delete Contract.....	24
Figure 15 - HD Create Lot.....	26
Figure 16 - HD Update Lot, add special note.....	27
Figure 17 - HD Delete Lot.....	29
Figure 18 - HD Create WorkOrder.....	31
Figure 19 - HD Modify Work Order.....	32
Figure 20 - HD Archive Work Order.....	33
Figure 21 - HD Retrieve Work Order.....	34
Figure 22 - HD Email Notification 24 hour.....	35
Figure 23 - HD Create Completion.....	36
Figure 24 - HD Close Completion.....	37
Figure 25 - HD Modify Completion.....	38
Figure 26 - Main Menu Interface.....	44
Figure 27 - Template for User Interface.....	45
Figure 28 - Lot Status Report.....	46
Figure 29 - Lot Closing Report.....	47
Figure 30 - Daily Superintendant Schedule.....	48
Figure 31 - Completion Report.....	49
Figure 32 - Work Order Report.....	49

Introduction

Tice River Homes is a home building company which oversees the production of pre-designed homes. They provide several options for house types based on lot sizes and features available to certain styles.

Our team will build a system for Tice River Homes that will allow the builder and its contractors to electronically track the status of each lot and manage outstanding and completed work orders. Work orders exist on a lot for any item which goes above and beyond a contractor's standard 'Scope of Work'. The system will allow the builder and contractors to check the status of any lot (including the closing date) so that they can prioritize their work.

The client wants a way to track all contract and extra work. 'Extras' are created when a home buyer chooses to upgrade an aspect of the house which goes outside the standard scope of work. The ability to maintain a manual system would require greater staff and decreased accuracy. The advantage of our system is it will allow Tice River to dynamically generate reports for the status of each and every lot. This will allow staff to keep on top of the latest developments onsite without having to consult with on-site personnel or to check manually.

Scope

This system will track many aspects of Tice River Homes' business. This section will clarify.

Features

Contractor Management Module

This module will keep track of all the contractors that Tice deals with. It will work with a database to keep up to date lists of who does what work, and this will allow the user to easily select completions and work orders when managing a lot.

Contract Management Module

This module will allow the user to begin the process of entering the information for a contract and tracking a lot and all its associated work. The contract that is agreed upon with the customer will become a lot that is tracked in the Lot Management Module.

Lot Management Module

Constructus
August 21, 2007

This module is the center of the system. Everything to do with building the home is connected to this module. Milestones can be set, work orders assigned, reports will be generated from the information stored in this module.

Report Generation Module

All the reports that Tice River Homes needs to track the status of its lots will be generated through this one, easy to use module.

Work Order Management Module

This module allows authorized users to enter, track and issue work orders for all extra work done on Tice River home lots. With this module, the user can see at a glance whether a particular “extra” item is being installed or built according to the time schedule, whether a work order has been issued already to the contractor responsible, and this module also works with the lot management module to keep the lot tracking up to date.

Completion Management Module

This module will track all contract portions of the home building process. All standard features are loaded into this module and the authorized user can use this module to issue completions to the contractors in order for them to receive payment from the Tice River Homes accounting department. When a contract is entered into the system in the Lot Management module, completions are automatically created for that job and their status is tracked in this module as they are finished.

Email Notification

The user can set their preferences for how often they would like email notification of lot status, milestone status – and this feature will create a system schedule for automatic deployment of formatted emails that are easy to read.

Backup of Virtual Machines

Part of what makes this system great is that it is so secure. With weekly backups, Tice River can feel safe knowing that their system is taking care of itself and that it is designed with the protection of their valuable data in mind. This module is designed so that the system will generate a call to do backups of all virtual machines. Backups of the virtual machine are simple file transfers and will allow for a complete backup of the system which can be redeployed in minutes.

Operating Environment

The system will operate on a server which runs Windows Server 2003 and will interface with Excel, Outlook. The system will use a PostgreSQL Database Management System. VMware Server will be used to host the application and database servers. The system will interface with the existing network.

VMware is a product used to virtualize servers. This allows one physical server, the host, to run multiple services, guests, concurrently. VMware allows our system to be moved from server to server with minimal effort. This enables easy scaling and simple disaster recovery options as the system is not tied to

the hardware in any way. The VMware server package will be installed on top of the Windows 2003 server. VMware Server has a zero cost license and an optional support package available.

Use Case Diagram

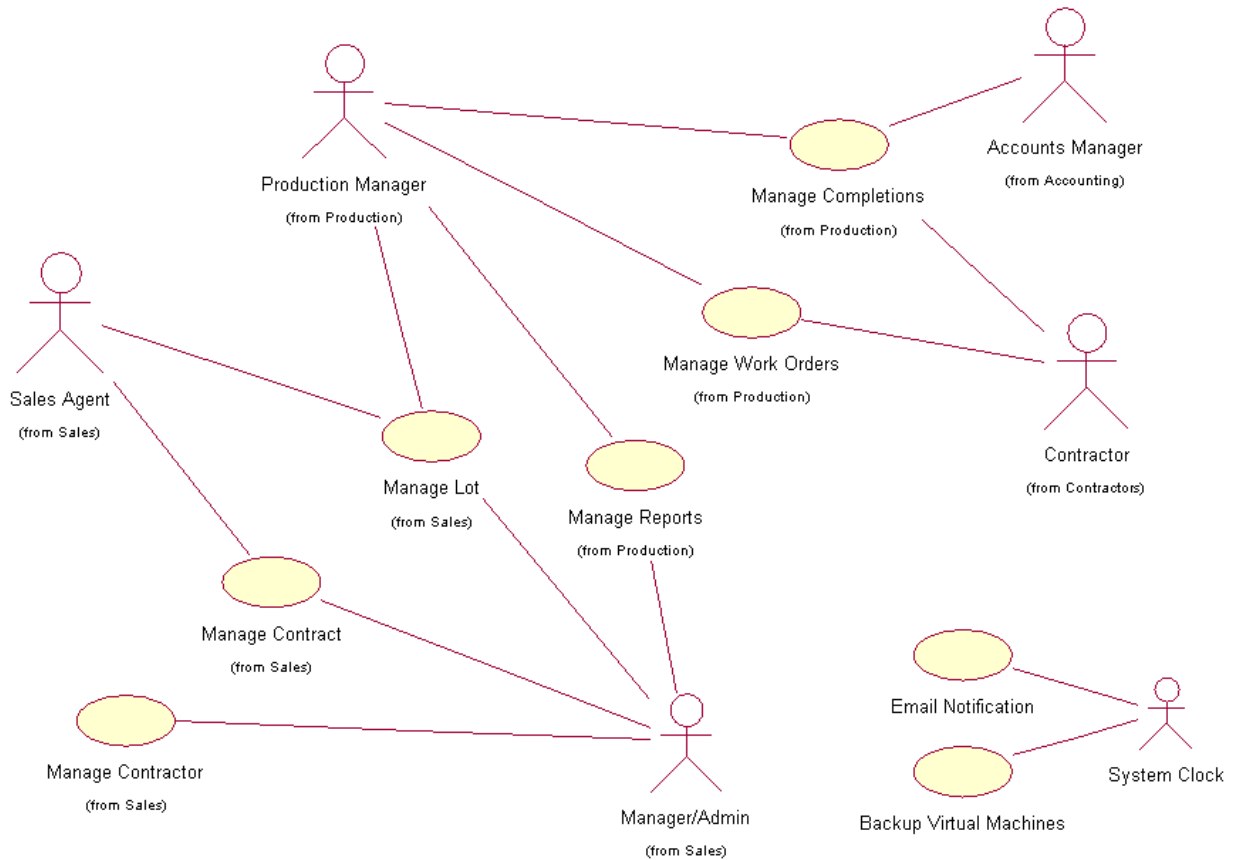

Figure 1 - Use Case Diagram

Scenarios and System Sequence Diagrams

HD Create Contractor

Preconditions

Contractor is insured
Contractor is licensed
Contractor is not in system
Contractor is authorized by manager
User is authorized
User is logged in
System is displaying main menu

Scenario

Actor Action	System Action
Actor selects "Manage Contractors" entry in main menu	System shows the user the "Manage Contractors" screen
Actor selects "New"	System prompts user for information about new contractor
Actor enters contractor name, contact information insurance provider, insurance number, license number, office telephone number, onsite contact number and address and selects "Save"	System saves the new information into the contractor information data store
Actor selects close	System returns to main menu

System Sequence Diagram

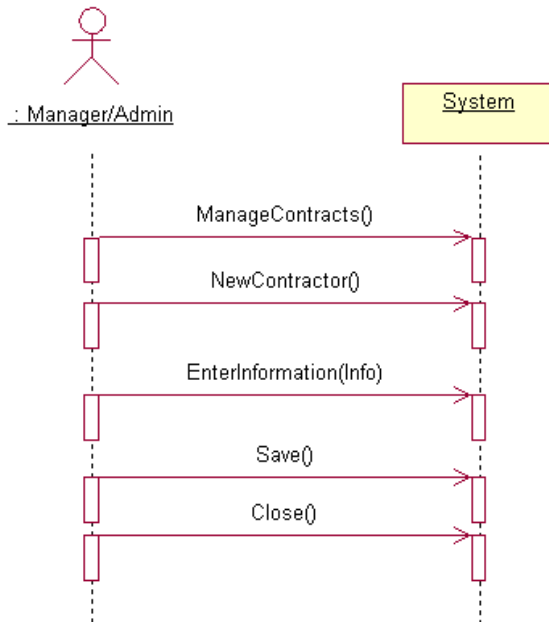

Figure 2 - HD Create Contractor

HD Update Contractor

Preconditions

- Contractor is in system
- User is authorized
- User is logged in
- System is displaying main menu

Scenario

Actor Action	System Action
Actor selects "Manage Contractors" entry in main menu	System shows the user the "Manage Contractors" screen
Actor selects "Load"	System shows the user a list of contractors
Actor selects a contractor	System loads values from contractor data store
Actor changes the name of the primary contact and selects "Save"	System saves the updated information into the contractor information data store
Actor selects close	System returns to main menu

System Sequence Diagram

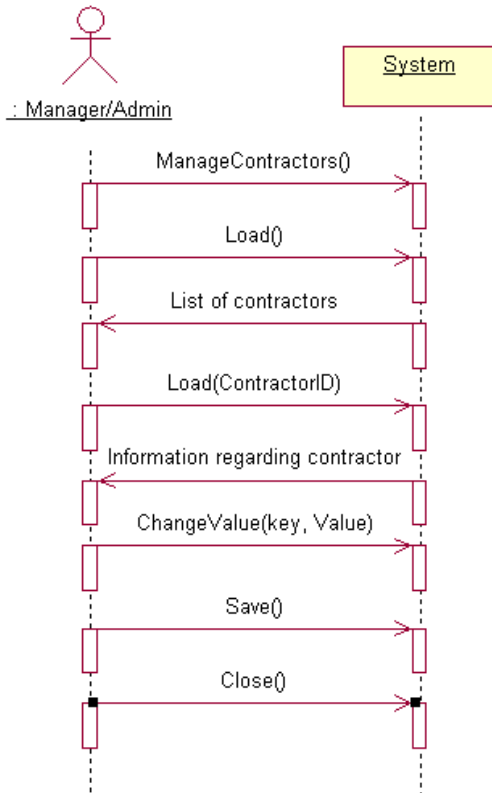

Figure 3 - HD Update Contractor

HD Delete Contractor

Preconditions

- Contractor is in system
- User is authorized
- User is logged in
- System is displaying main menu

Scenario

Actor Action	System Action
Actor selects "Manage Contractors" entry in main menu	System shows the user the "Manage Contractors" screen
Actor selects "Load"	System shows the user a list of contractors
Actor selects a contractor	System loads values from contractor data store
Actor Selects "Delete"	System flags the loaded contractor as deleted. Contractor information including the "hidden" flag is

	saved
Actor selects close	System returns to main menu

System Sequence Diagram

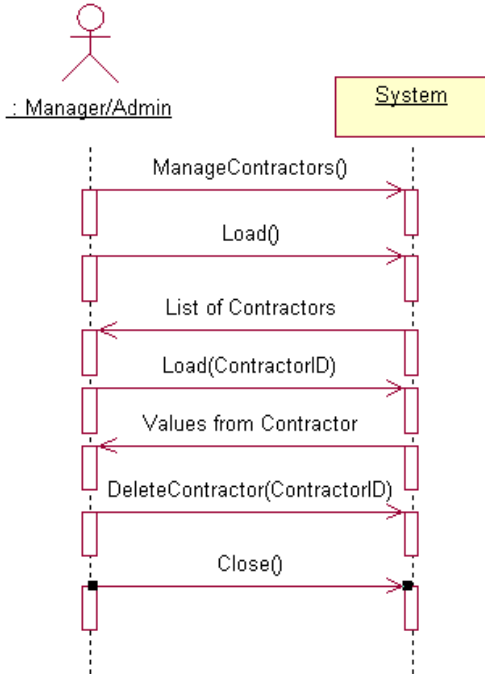

Figure 4 - HD Delete Contractor

HD Backup Virtual Machines

Preconditions

- System clock is 1AM on Saturday evening
- There is enough free space on the server for the backup
- There is enough space on the remote backup site
- No critical jobs are executing

Scenario

Actor Action	System Action
Clock strikes 1:00AM	System alerts all users that the system is backing up and will be unavailable for a short time.
Clock strikes 1:30AM	System turns off all access to the system.
	System stops all running virtual machines
	System copies virtual machine files to primary backup site and remote backup site
	System restarts virtual machines

System Sequence Diagram

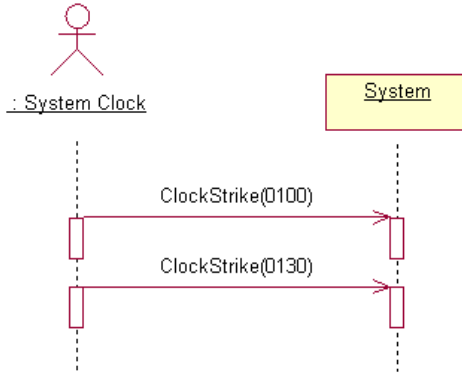

Figure 5 - HD Backup Virtual Machines

HD Create Lot Status Report

Preconditions

The user is logged in

The system is displaying the main menu

Scenario

Actor Action	System Responsibility
Selects the Manage Reports option	Returns a list of all configurable reports.
Selects Create Lot Status Report	Returns options for Lot Status Report (Project/Phase/Lot No/Include Work Orders)
Enters the Project, Phase and Lot No. to obtain a status report on. (also indicates to include work orders)	Fetches all completion and work orders which pertain to the lot (outstanding and completed). Returns complete lot information (buyer, closingdate, model, frontage, elevation, buyer, municipaladdress) including estimated and actual dates and percentage complete for all items.
* Selects Export to PDF (see Extension)	
Selects Exit.	Closes the Manage Reports menu and returns to the main menu.

Extensions:

* User chooses to Export to PDF once the Report is prepared: *HD Export to PDF*

System Sequence Diagram

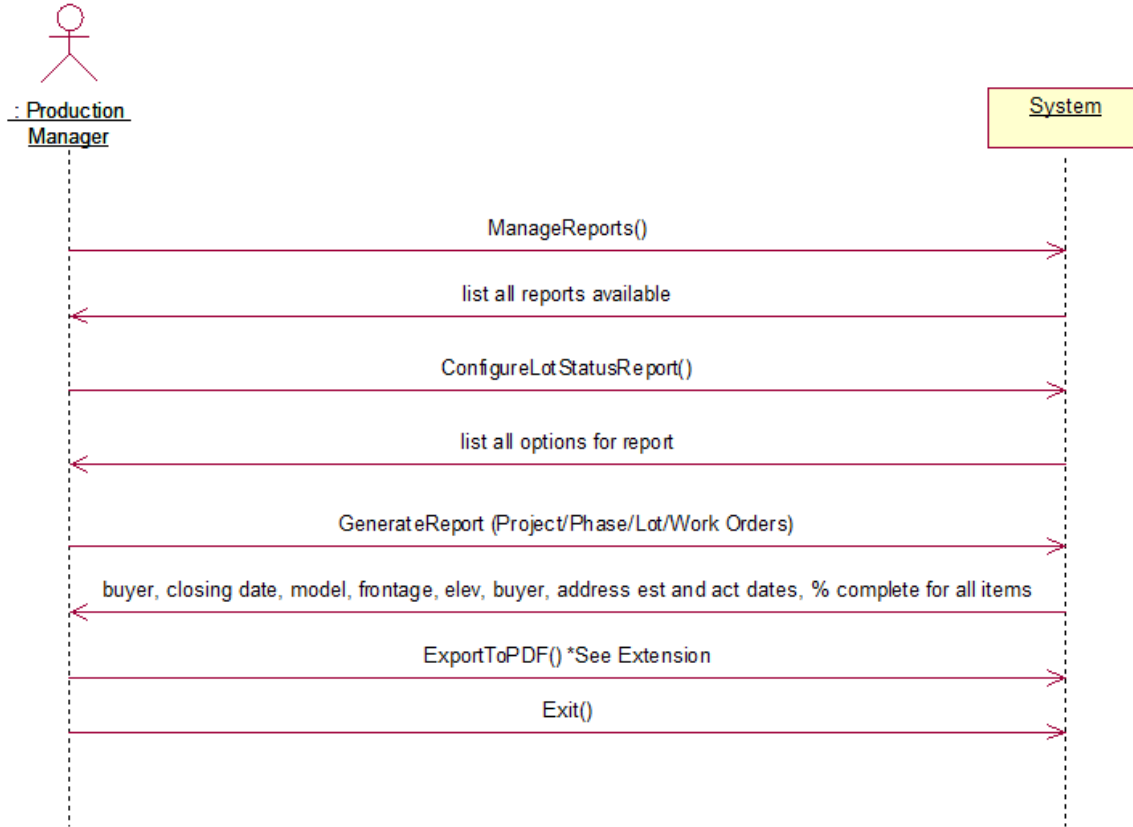

Figure 6 - HD Create Lot Status Report

HD Create Lots Closing Report

Preconditions

The user is logged in

The system is displaying the main menu

Scenario

Actor Action	System Responsibility
Selects the Manage Reports option	Returns a list of all configurable reports.
Selects Create Lots Closing Report	Lists options for Lots Closing Report (Date Range: Start & End/Project/Phase)
Enters the Project, Phase, the Start and End Dates.	Fetches all lots which actively exist for that Project/Phase within the specified date range and returns the data in ascending order (soonest closing at the top).
* Selects Export to PDF (see Extension)	
Selects Exit.	Closes the Manage Reports menu and returns to the main menu.

Extensions:

* User chooses to Export to PDF once the Report is prepared: HD Export to PDF

System Sequence Diagram

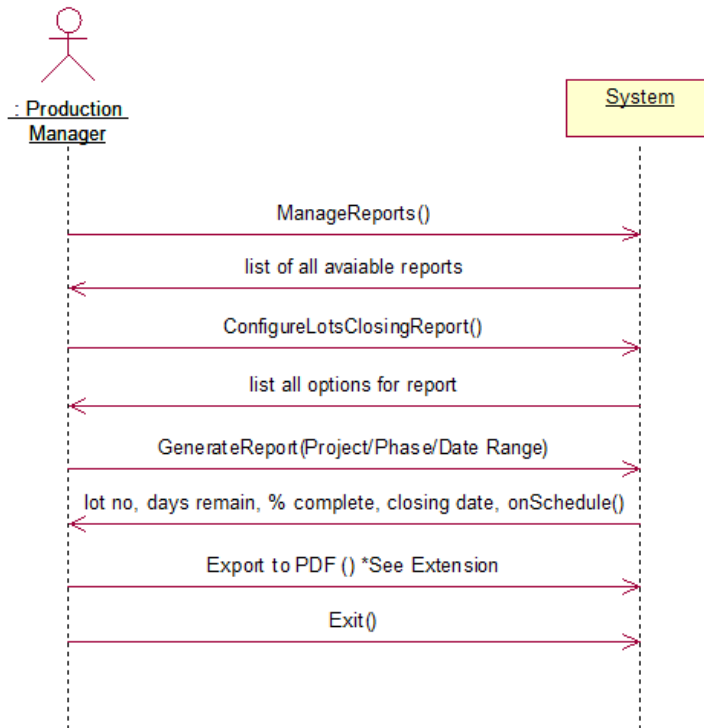

Figure 7 - HD Create Lots Closing Report

HD Create Daily Superintendent Schedule

Preconditions

The user is logged in

The system is displaying the main menu

Scenario

Actor Action	System Responsibility
Selects the Manage Reports option	Returns a list of all configurable reports.
Selects Create Daily Superintendent Schedule	Returns option to exclude Work Orders (Extras)
Enters to exclude work orders.	Fetches all milestones (aka Tasks Scheduled) active (in progress/starting/finishing) on that date and sorts them by lot and by trade. Produces a list of upcoming tasks to be scheduled for the proceeding days. *
** Selects Export to PDF (see Extension)	
Selects Exit.	Closes the Manage Reports menu and returns to the main menu.

Extensions:

* All scheduled dates (start/end) are calculated by the system. Each milestone (or Task Scheduled) is placed in a sequence and given a weight (e.g. this milestone accounts for 2% of construction of the home). Since the milestones are placed sequentially the system can calculate (based on the required date (aka Closing Date) when each task is to be performed by). The system is flexible; when actual completion dates are entered it re-projects the remaining work to be done and adjusts the schedule accordingly. Herein lays the power of our system; it will be able to quickly reschedule the work remaining to keep the house on schedule. This note has been written for clarification regarding where tasks scheduled are entered, as can be seen from the above explanation they are not entered but rather calculated based on tasks and time remaining before the Closing date.

** User chooses to Export to PDF once the Report is prepared: *HD Export to PDF*

System Sequence Diagram

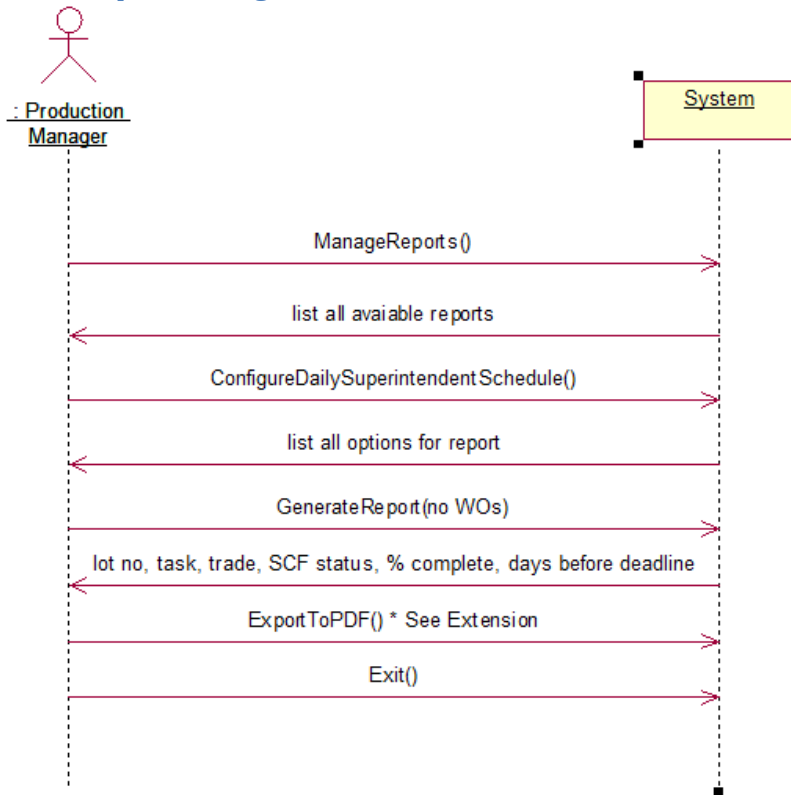

Figure 8 - HD Create Daily Superintendent Schedule

HD Create Completion Report

Preconditions

The user is logged in

The system is displaying the main menu

Scenario

Actor Action	System Responsibility
Selects the Manage Reports option	Returns a list of all configurable reports.
Selects Create Completion Report	Returns options to include: Project/Phase/issued completions/ready (not issued) completions/pending (not yet done) completions/for all lots or one specific lot.
Enters Project and Phase and includes ready and pending completions for all lots	Fetches completions for lots in the project/phase specified. Grouped by lot and sorted in ascending order and returns the data.
* Selects Export to PDF (see Extension)	

Selects Exit.	Closes the Manage Reports menu and returns to the main menu.
---------------	--

Extensions:

* User chooses to Export to PDF once the Report is prepared: HD Export to PDF

System Sequence Diagram

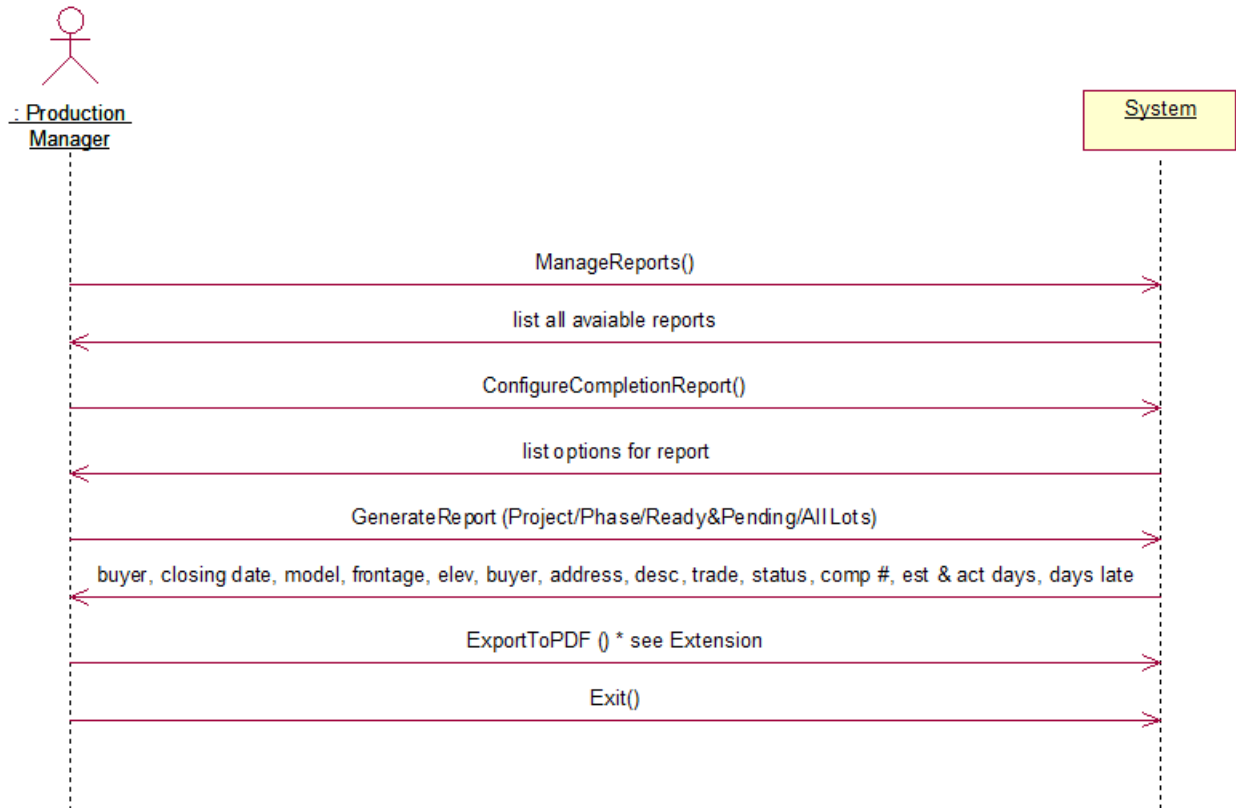

Figure 9 - HD Create Completion Report

HD Create Work Order Report

Preconditions

The user is logged in

The system is displaying the main menu

Scenario

Actor Action	System Responsibility
Selects the Manage Reports option	Returns a list of all configurable reports.
Selects Create Work Order Report	Returns options to include: Project/Phase/issued work order/ready (not issued) work order/pending (not yet done) work order/forall lots or one specific lot.
Enters Project and Phase and includes issued work orders for all lots	Fetches all issued work orders for lots in the project/phase specified. Grouped by lot and sorted in ascending order and returns the data.
* Selects Export to PDF (see Extension)	
Selects Exit.	Closes the Manage Reports menu and returns to the main menu.

Extensions:

* User chooses to Export to PDF once the Report is prepared: *HD Export to PDF*

System Sequence Diagram

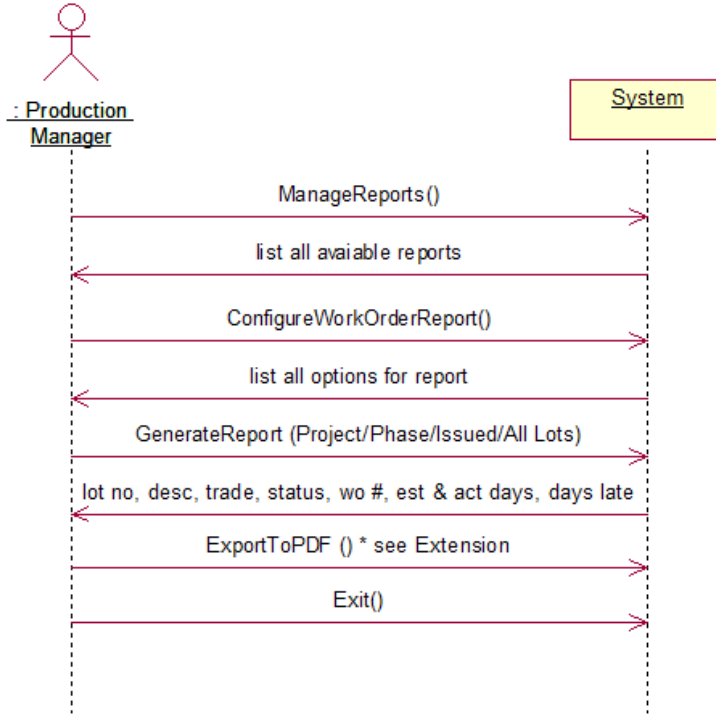

Figure 10 - HD Create Work Order Report

HD Export to PDF

Preconditions

The user is logged in
The system has been forwarded to Export to PDF by the User.

Scenario

Actor Action	System Responsibility
Selected Export to PDF	System prepares the report for the printer, rather than sending the output to a standard printer it sends the information to the PDF printer, which prompts the user for a location to save the PDF. *Note PDF printers do not actually print anything, they just capture the print job and output to PDF file for saving.
Selects location to save PDF and chooses SAVE.	System saves the PDF document and returns to the caller that it was successful.

System Sequence Diagram

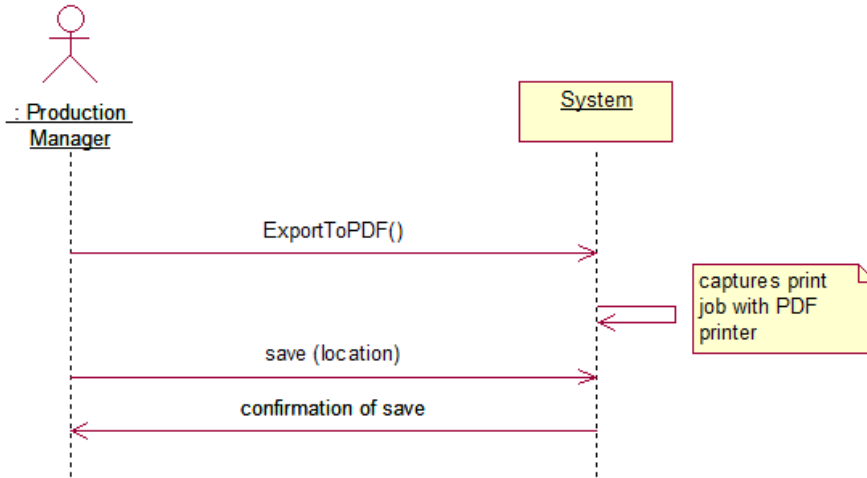

Figure 11 - HD Export to PDF

HD Create Contract

Preconditions:

- The user is logged in
- The system is displaying the main menu

Scenario

Actor Action	System Responsibility
Selects the Manage Contracts option	Displays the Manage Contract screen. A prompt is sent asking the user to select a project and phase number from a pull-down menu.
Chooses the project, phase number and lot number from the pull-down menu and selects the Open Project option	Sends the project's contract information to the Manage Contract screen. In this case, since no contract currently exists, a message will be sent saying no contract exists for this project.
Selects the Create Contract option on the Manage Contract screen	Displays the Create Contract screen
Enters the data for the new contract. This data includes the buyer's name and date of birth, the lot number, lot address, model, plan type, approx. frontage, date of offer, irrevocable date, closing date, buyer's address, and buyer's phone number	
Selects the Create option	Creates the new contract by saving it in the database, closes the Create Contract screen and updates the Manage Contract Screen with the new contract

	information.
Selects Exit	Closes the Manage Contract screen, redisplay the main menu and the scenario ends.

System Sequence Diagram

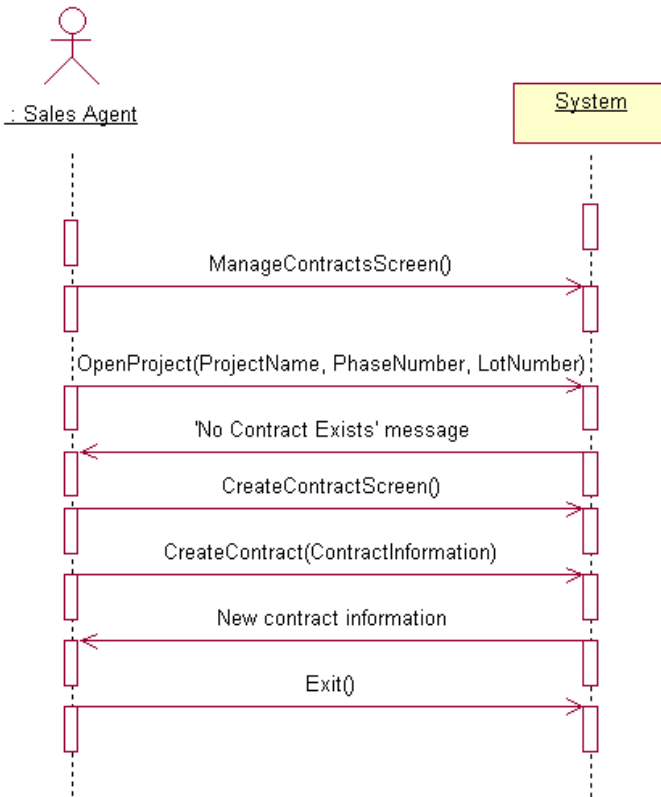

Figure 12 - HD Create Contract

HD Update Contract, change lot number

Preconditions:

The user is logged in

The system is displaying the main menu

Scenario

Actor Action	System Responsibility
Selects the Manage Contracts option	Displays the Manage Contract screen. A prompt is sent asking the user to select a project and phase number from a pull-down menu.
Chooses the project, phase number and lot number from the pull-down menu and selects the Open Project option	Sends the project's contract information to the Manage Contract screen.
Selects the Update Contract option on the Manage Contract screen	Displays the Update Contract screen and sends the contract's data to be displayed in the fields.
Enters the new lot number	
Selects the Update option	Updates the contract by re-saving it in the database, closes the Create Contract screen and updates the Manage Contract Screen with the new contract information.
Selects Exit	Closes the Manage Contract screen, redisplay the main menu and the scenario ends.

System Sequence Diagram

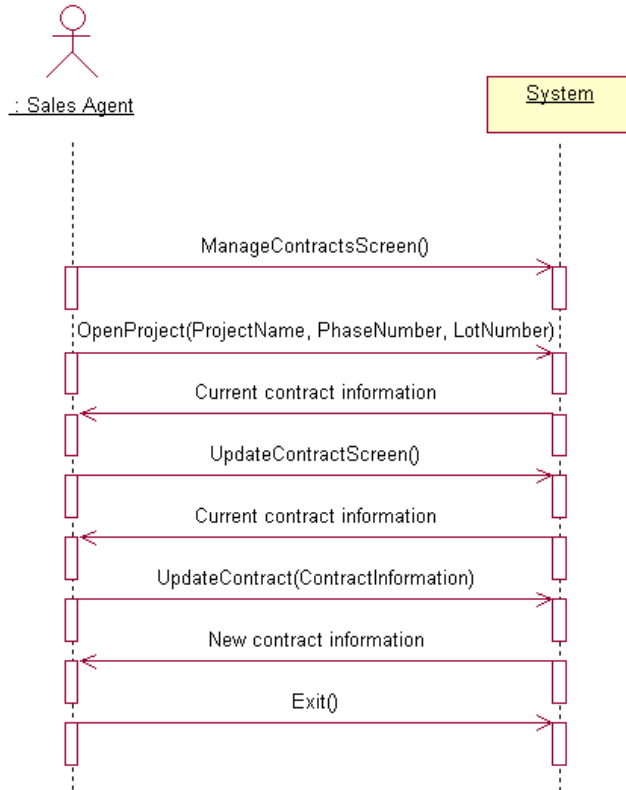

Figure 13 - HD Update Contract

HD Delete Contract

Preconditions:

- The user is logged in
- The system is displaying the main menu

Scenario

Actor Action	System Responsibility
Selects the Manage Contracts option	Displays the Manage Contract screen. A prompt is sent asking the user to select a project and phase number from a pull-down menu.
Chooses the project and phase number from the pull-down menu and selects the Open Project option	Sends the project's contract information to the Manage Contract screen.
Clicks the Delete Contract button on the Manage Contracts screen	A prompt is sent asking the user if he/she is sure that they want to delete the contract, with 2 options (OK and Cancel)
Clicks the OK button on the prompt	Deletes the contract from the database, closes the Create Contract screen and updates the Manage

	Contract Screen with the new contract informaton. In this case, since no contract currently exists, a message will be sent saying no contract exists for this project.
Selects Exit	Closes the Manage Contracts screen, redisplay the main menu and the scenario ends.

System Sequence Diagram

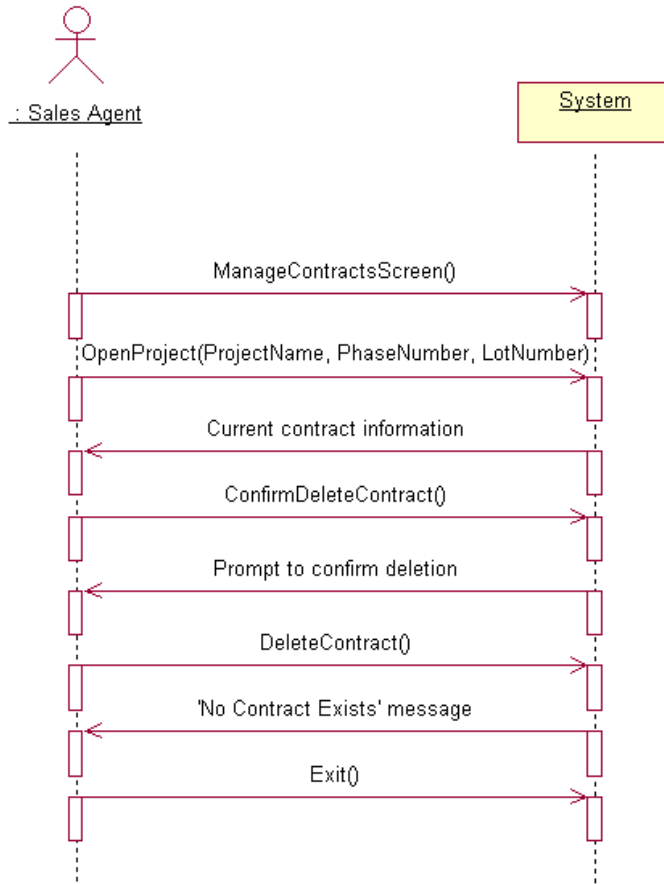

Figure 14 - HD Delete Contract

HD Create Lot

Preconditions:

The user has logged in to the system

The system is displaying the Main Menu

Scenario

Actor Action	System Responsibility
Selects the Manage Lots option	Displays the Manage Lots screen. Sends a prompt asking the user to select a project and phase number from a pull-down menu.
Chooses a project and phase number from the pull-down menu and selects the Open Project option	Populates a pull-down menu in the Manage Lots screen with a list of all of the project's current lots.
Selects the Create Lot option on the Lot screen	Displays the Create Lot screen
Enters the data for the new lot. This data includes the lot number, subdivision, phase, street name, model, elevation, plan number, plan type, siting, grade, and optional special notes	
Selects the Create option	Creates the new lot in the database, closes the Create Lot screen and updates the pull-down list of lots in the Manage Lots screen
Selects Exit	Closes the Manage Lots screen, redisplay the main menu and the scenario ends.

System Sequence Diagram

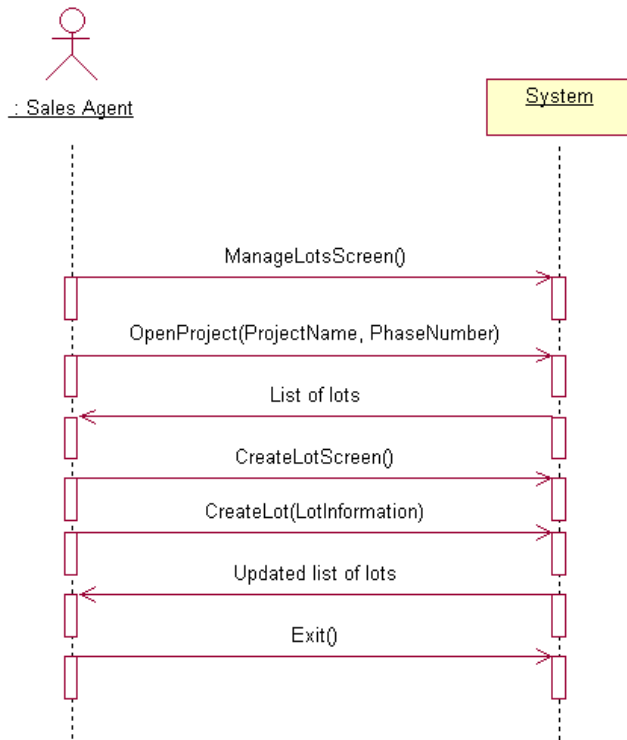

Figure 15 - HD Create Lot

HD Update Lot, add special note

Preconditions:

- The user has logged in to the system
- The system is displaying the Main Menu

Scenario

Actor Action	System Responsibility
Selects the Manage Lots option	Displays the Manage Lots screen. Sends a prompt asking the user to select a project and phase number from a pull-down menu.
Chooses a project and phase number from the pull-down menu and selects the Open Project option	Populates a pull-down menu in the Manage Lots screen with a list of all of the project's current lots.
Selects the lot in the pull-down menu that the user would like to update	Reacts to the update in the pull-down menu's changed selection by sending that lot's information to the Manage Lots screen.
Clicks on the Update Lot button	Displays the Update Lot screen and sends that lot's data to be displayed in the fields.
Adds a special note to the lot	

Selects the Update option	Updates the lot by re-saving the information in the database and closes the Update Lot screen. Sends the updated information to the Manage Lots screen.
Selects Exit	Closes the Manage Lots screen, redisplay the main menu and the scenario ends.

System Sequence Diagram

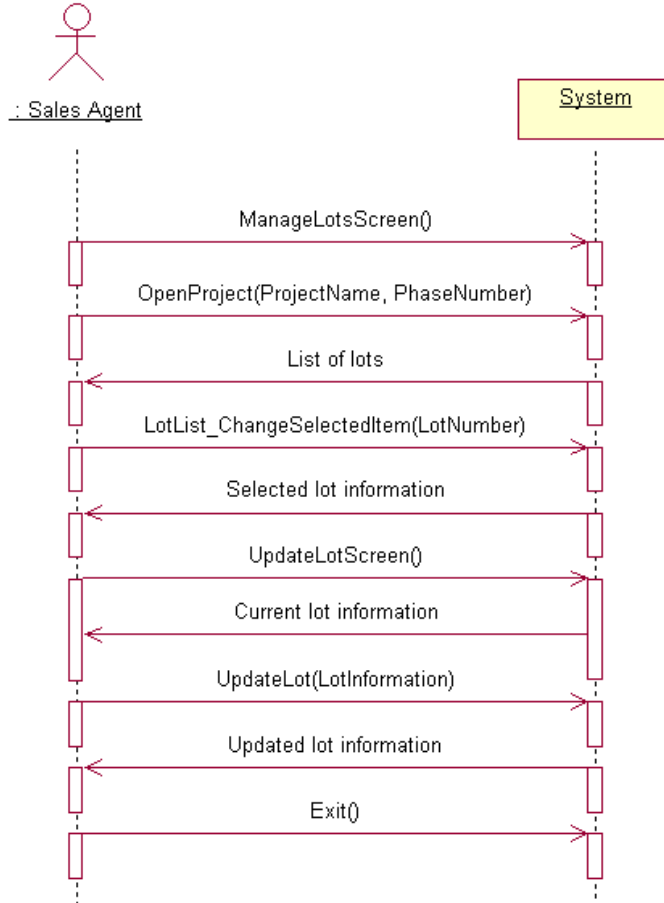

Figure 16 - HD Update Lot, add special note

HD Delete Lot

Preconditions:

The user has logged in to the system

The system is displaying the Main Menu

Scenario

Actor Action	System Responsibility
Selects the Manage Lots option	Displays the Manage Lots screen. Sends a prompt asking the user to select a project and phase number from a pull-down menu.
Chooses a project and phase number from the pull-down menu and selects the Open Project option	Populates a pull-down menu in the Manage Lots screen with a list of all of the project's current lots.
Selects the lot in the pull-down menu that the user would like to update	Reacts to the update in the pull-down menu's changed selection by sending that lot's information to the Manage Lots screen.
Clicks on the Delete Lot button on the Manage Lots screen	A prompt is sent asking the user if he/she is sure that they want to delete the contract, with 2 options (OK and Cancel)
Clicks the OK button on the prompt	Deletes the lot from the database and updates the pull-down menu with an updated list of current lots.
Selects Exit	Closes the Manage Lots screen, redisplay the main menu and the scenario ends.

System Sequence Diagram

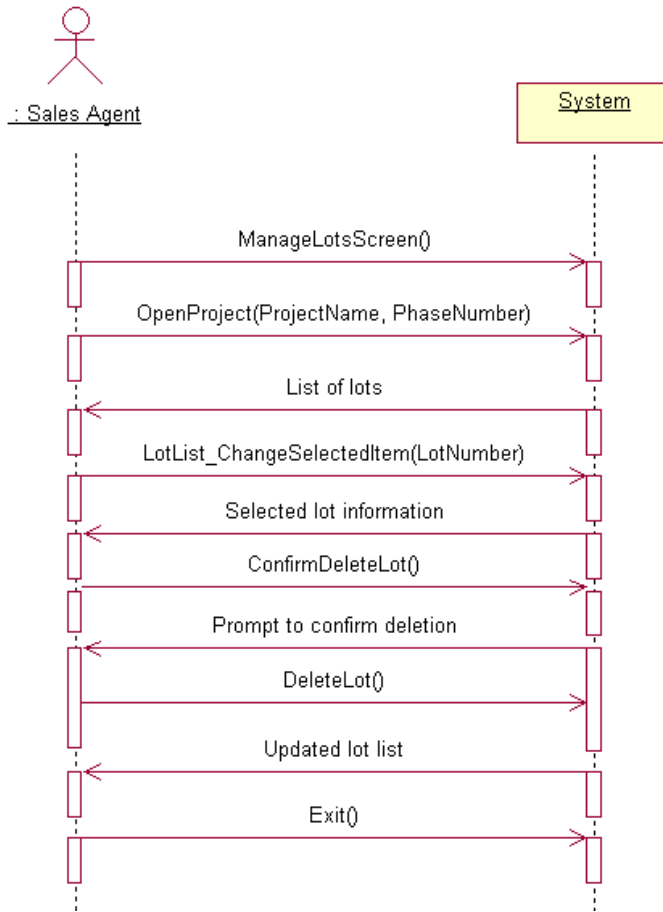

Figure 17 - HD Delete Lot

HD Create Work Order

Preconditions:

- The lot has been released
- The contract is in the system
- The user is logged in and authorized to access this area
- The system is displaying the Main Menu.

Scenario

Actor Action	System Responsibility
Selects "Manage Work Order" from the main menu	Display the Manage work order menu with options for create, modify, retrieve (find), and archive as well as a Main Menu link.

Selects "Create" from the Manage Work Order menu	Display a blank work order form
Selects "Find Contractor" from the work orderscreen	Pop up box created which allows for searching by name, specialty or contractor id number. If the contractor is not located, has the option to go to "add a contractor" if the user has sufficient access rights.
Selects a contractor from the search results and the information is filled into the work order form	
Enters the information for the work order; description, lot number, hours projected,start date, end date, cost estimate	
Selects "Save"	System assigns a unique work order number and saves the work order to theopen work orders file, returns a feedback field that states the successof the save
Selects "Main Menu"	System returns to main menu and the scenario ends.

System Sequence Diagram

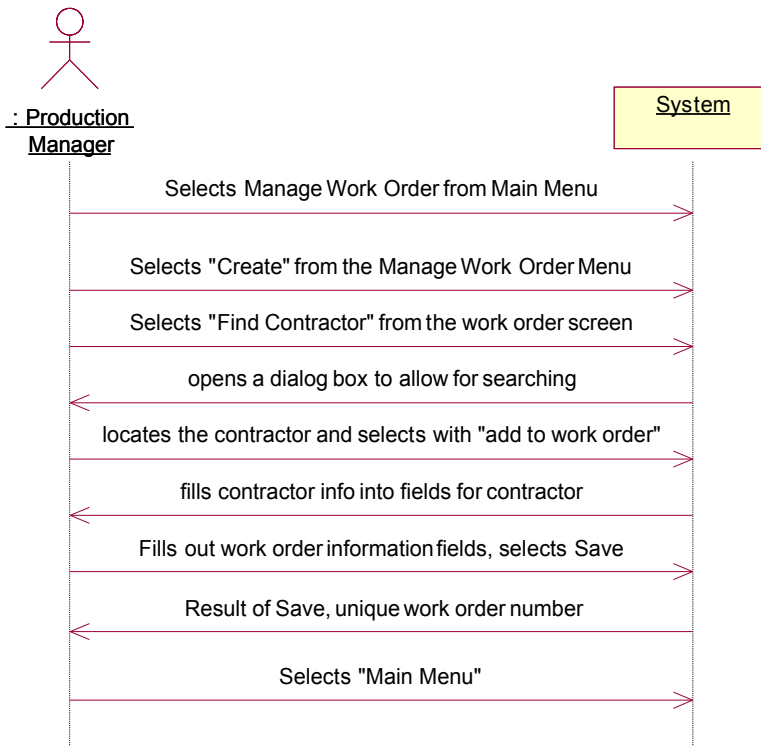

Figure 18 - HD Create Work Order

HD Modify Work Order

Preconditions:

Work order exists in system

Scenario

Actor Action	System Responsibility
Selects "Manage Work Order" from the main menu	Display the Manage work order menu with options for create, modify, retrieve (find), and archive as well as a Main Menu link.
Selects "Modify" from the Manage Work Order menu	System displays pop up window with a field to enter the work order number
Enters the work order number and selects "Go"	System displays the work order screen with all the information for the work order
Enters new information...name change or estimate change - selects "Save"	System saves the work order to file and returns with a feedback field that states the success of the update.
Selects "Main Menu"	System returns to main menu and the scenario ends.

System Sequence Diagram

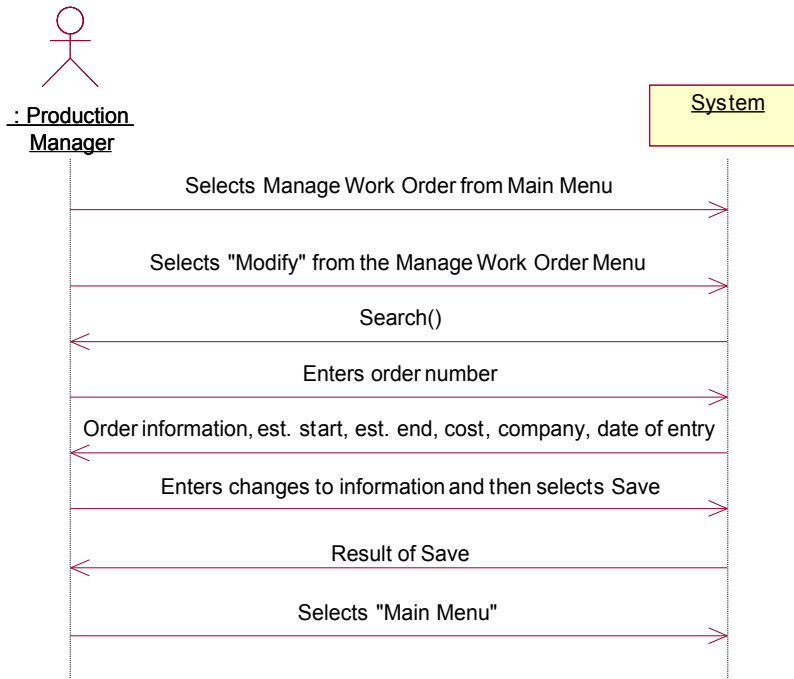

Figure 19 - HD Modify Work Order

HD Archive Work Order

Preconditions:

Work order exists in system

Scenario

Actor Action	System Responsibility
Selects "Manage Work Order" from the main menu	Display the Manage work order menu with options for create, modify, retrieve (find), and archive as well as a Main Menu link.
Selects "Archive" from the Manage WorkOrder menu	System displays popup window with a field to enter the work order number
Enters the work order number and selects "Go"	System displays the work order screen with all the information for the work order
Selects "Archive This Order"	System displays a confirmation window - "Are you sure you want to archive this order?" with "Yes" and "No" buttons
Selects "Yes"	System saves the work order to the archived work orders file and displays a feedback field with the success of the archiving. System displays the Manage Work Order sub Menu and the scenario ends

System Sequence Diagram

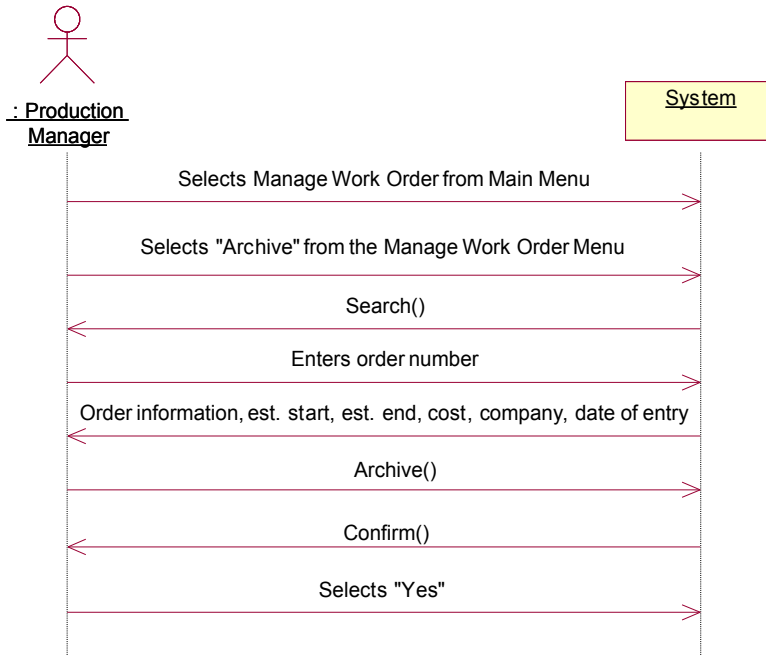

Figure 20 - HD Archive Work Order

HD Retrieve Work Order

Preconditions:

Work order exists in system and is in the archived file

Scenario

Actor Action	System Responsibility
Selects "Manage Work Order" from the main menu	Display the Manage work order menu with options for create, modify, retrieve (find), and archive as well as a Main Menu link.
Selects "Retrieve" from the Manage Work Order menu	System displays popup window with a field to enter the work order number
Enters the work order number and selects "Go"	System displays the work order screen with all the information for the work order – Read Only
Selects "De-Archive"	System saves the work order to the open work orders file and displays a feedback field with the success of the de-archiving. System displays the Manage Work Order sub Menu and the scenario ends

System Sequence Diagram

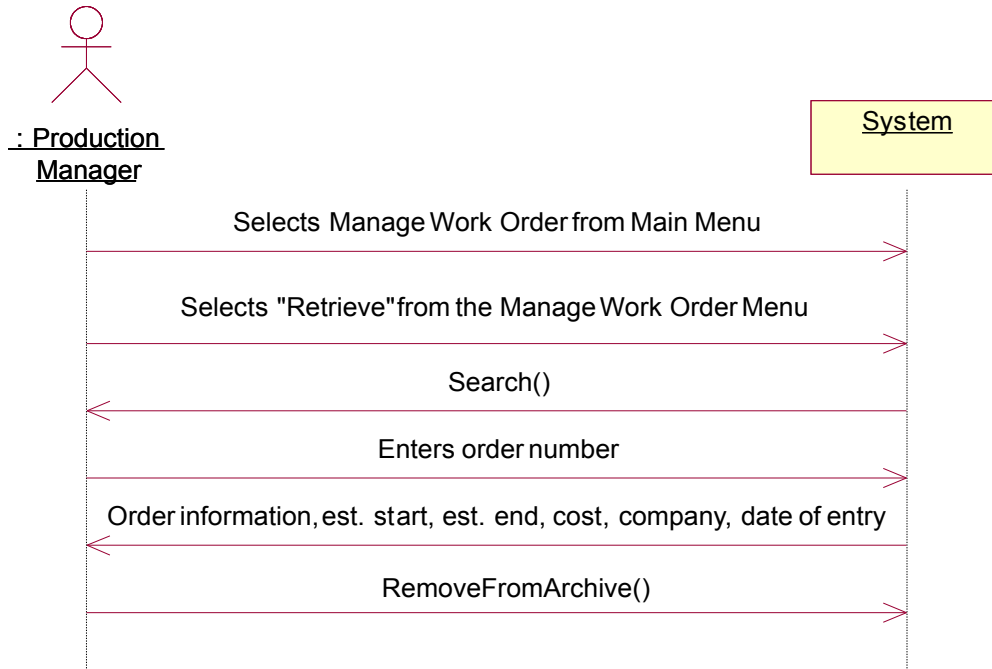

Figure 21 - HD Retrieve Work Order

HD Email Notification - 24hour

Preconditions:

Email notification preference is enabled and set to 24 hours reminders
There is an email program configured with the system for outgoing mail

Scenario

Actor Action	System Responsibility
System Clock strikes 5:00pm	System locates all active milestones and creates and sends a formatted email to the administrator

System Sequence Diagram

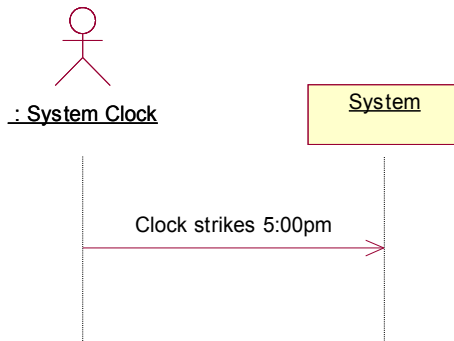

Figure 22 - HD Email Notification 24 hour

HD Create Completion

Preconditions:

User is authorized to create completions

Scenario

Actor Action	System Responsibility
Selects "Manage Completions" from Main Menu	Displays the Manage Completions menu with Create, Modify, Close options
Selects "Create"	System displays a blank Completion Information form page
Fills in the information about the completion; lot style, type, completion name, trade, cost	
Selects "Save"	Assigns a completion ID number and saves the completion to the completions file
Selects "Main Menu"	The system displays the main menu and the scenario ends

System Sequence Diagram

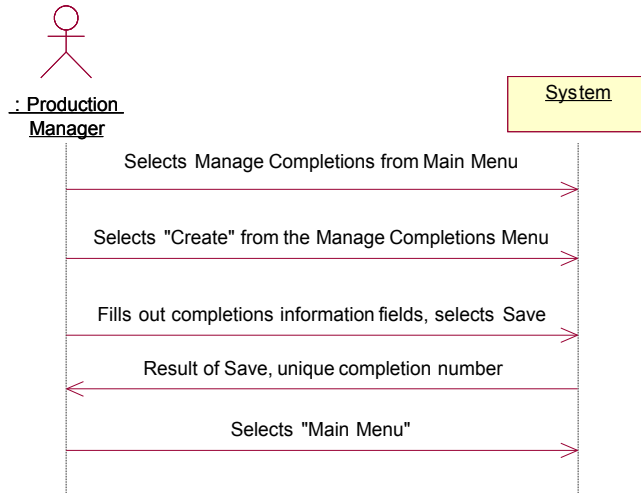

Figure 23 - HD Create Completion

HD Close Completion

Preconditions:

User is authorized to close completions

Scenario

Actor Action	System Responsibility
Selects "Manage Completions" from Main Menu	Displays the Manage Completions menu with Create, Modify, Close options
Selects "Close" from the Manage Work Order menu	System displays popup window with a field to enter the completion number
Enters the completion number and selects "Go"	System displays the completion information screen with all the information for the completion requested
Changes status of the completion and selects "Save"	Saves the new information to the completions file
Selects "Main Menu"	The system displays the main menu and the scenario ends

System Sequence Diagram

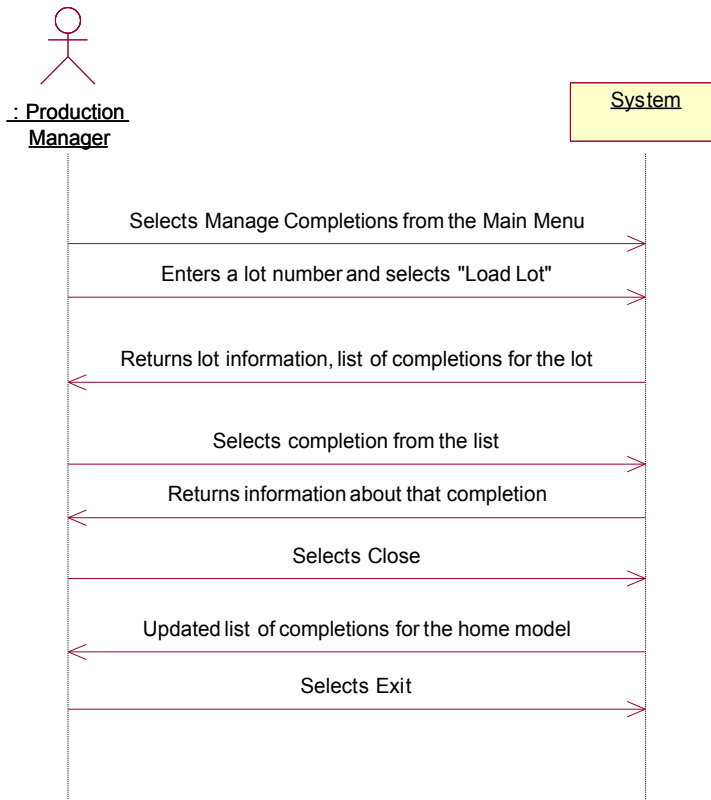

Figure 24 - HD Close Completion

HD Modify Completion

Preconditions:

User is authorized to modify completions

Scenario

Actor Action	System Responsibility
Selects "Manage Completions" from Main Menu	Displays the Manage Completions menu with Create, Modify, Close options
Selects "Modify" from the Manage Work Order menu	System displays popup window with a field to enter the completion number
Enters the completion number and selects "Go"	System displays the completion information screen with all the information for the completion requested
Updates any fields as required and selects "Save"	Saves the new information to the completions file
Selects "Main Menu"	The system displays the main menu and the scenario ends

System Sequence Diagram

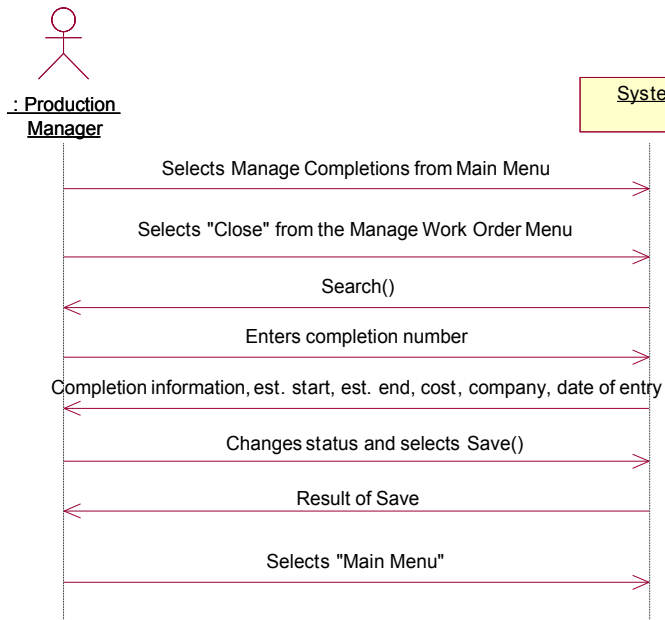

Figure 25 - HD Modify Completion

Stakeholders

Key stakeholders in the system are identified as follows:

- The president of Tice River Homes, Ray Di Donato who needs a reliable system to track his developments
- Team 2 who want to develop a strong, usable system
- Contractors who will benefit from the automation of the paperwork involved with completions and work orders
- Customers who will benefit from Tice River having a better way to track the status of their future home

Business Rules

The following is a list of business rules which will define and constrain the system.

- A contract must be in place in order to release a lot
- Contracts must be approved by head office
- Work orders are only created for "Extras to contract"
- Completions are only created for standard features
- All completed lots will be archived and backed-up for future reference
- Only approved contractors can be assigned work orders
- Invoice back-up (completions and work orders) must be provided for payments to be issued to Contractors
- Work orders and completions cannot be issued for lots that have not been released
- All contracts are confidential and can only be accessed by authorized personnel
- A contract can only be deleted if it is agreed upon by both the client and Tice River Homes.
- A contract can only be deleted before the irrevocable date.

Implementation Plan for Use Cases

Our first iteration will include setting up VMware and installing guest operating systems. The Database will also be set up with a script written by Team 2. Manage Contractor and Manage Lot will be the first use cases to be developed as they are the basis for all future iterations and are referenced by almost all other use cases.

The second iteration will include Manage WorkOrders and Manage Completions because these use cases describe core functionality of the system. Upon completion there will be a functioning system which provides value to Tice River Homes. This iteration will build on the existing infrastructure.

Constructus
August 21, 2007

The third iteration will include the Manage Contract and Manage Reports use cases. This iteration will focus on completing the major business value proposition of the system. This iteration will also build on existing infrastructure.

The fourth and final iteration will include the Email Notifications and Backup Virtual machines use cases. These use cases represent the smallest aspects of the system. The Backup Virtual machines use case will require the use of the VMware VIX API for backup operations. The Email Notifications use case will require an e-mail sending system be deployed.

Appendix A:
Log of meetings with client

Log of meetings with Ray

Date	Time	Place	Description
May 27, 2007	10:00AM	Ray's Home	-Discussed/Proposed system ideas -Decided on construction tracking system -Discussed system requirements (see Project Proposal)
June 8, 2007	9:00AM	Ray's Office	-Discussed in further detail the specifics of the system -Discussed Business Rules with Ray -Asked Ray to prepare of list of Reports the system would be required to produce
July 17, 2007	10:00AM	Ray's Office	-Showed Ray screen templates, he approved the concept and gave us the description for the five major reports needed
July 27, 2007	11:00AM	Ray's Office	-Reviewed with Ray the reports that would be required for the system by reviewing our mockups of these reports.
August 8, 2007	2:00PM	Ray's Office	-Discussed the finer points of the tracking system including: the ability to calculate/schedule the work that needs to be done to meet certain closing dates.

Appendix B: Screen and Report Templates

Screens

Main Menu

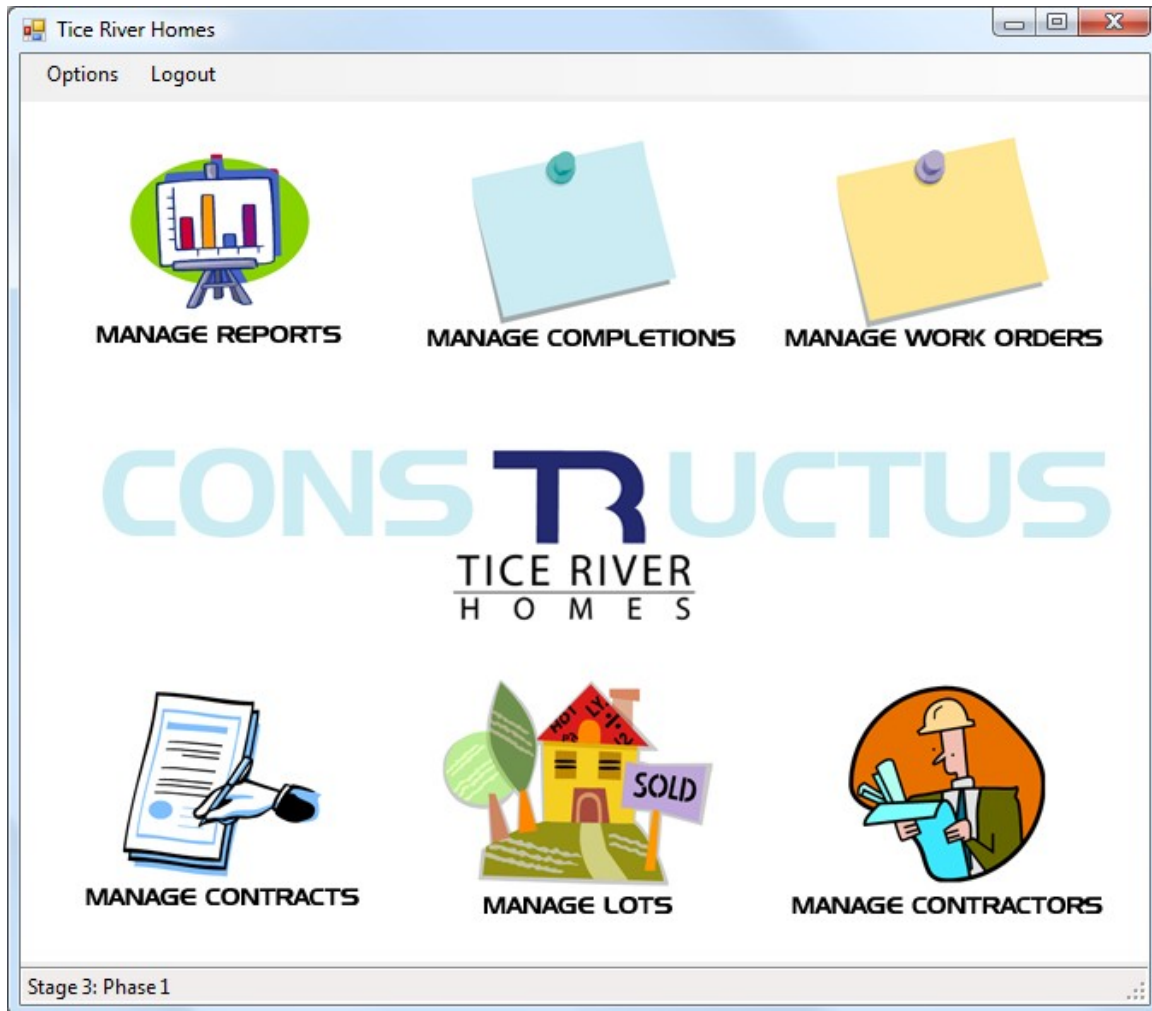

Figure 26 - Main Menu Interface

User Interface Template

The screenshot shows a web application window titled "Tice River Homes" with a standard Windows-style title bar (minimize, maximize, close buttons). The main content area is a form titled "Lot Information" with a sub-header "Options Logout". The form contains several input fields and checkboxes:

Field	Value	Field	Value	Field	Value
Project	Hilltop Estates (Stage 3)	Owner	Mr. & Mrs. Ryan	Status	In Progress
Phase	1	Address	101 Hilltop Drive, Ayr	<input checked="" type="checkbox"/>	Released for Construction
Lot No.	1	Closing Date	April 16, 2009	<input checked="" type="checkbox"/>	Lot Reserved
Model	Victoria Comer (50-13) B, 4 BRs, 3.5 Baths			<input checked="" type="checkbox"/>	Building Permit Issued

At the bottom of the window, there is a status bar displaying "Stage 3: Phase 1 - Lot 1".

Figure 27 - Template for UserInterface

Reports

Lot Status Report



Lot Status Report



Project:	Hilltop Estates Stage 3	Buyer:	Mary Ryan	Date:	12-Aug-07
Phase:	1	Address:	48 Hilltop Drive	Closing Date:	15-Dec-07
Lot:	48	Elevation:	B		
Model:	Rose Hill (43-2)	Frontage:	15.0m		

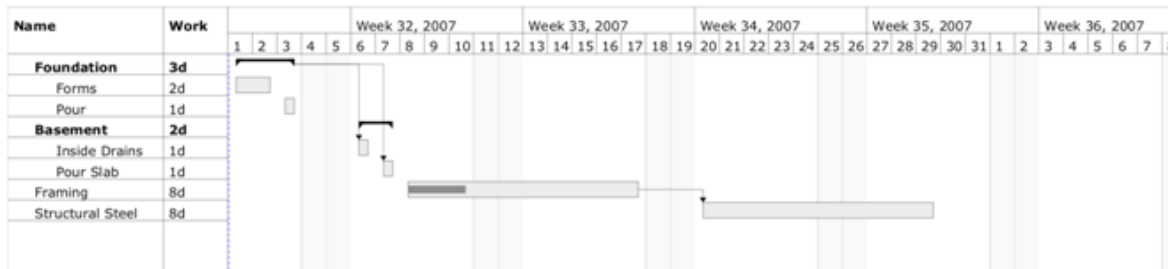

Item	Description	%	Estimated	Actual	Estimated	Actual
			Start	Start	End	End
1	Foundation	100%	01-Aug-07	01-Aug-07	03-Aug-07	03-Aug-07
1.1	Forms	100%	01-Aug-07	01-Aug-07	02-Aug-07	02-Aug-07
1.2	Pour	100%	03-Aug-07	03-Aug-07	03-Aug-07	03-Aug-07
2	Basement	100%	06-Aug-07	06-Aug-07	07-Aug-07	07-Aug-07
2.1	Inside Drains	100%	06-Aug-07	06-Aug-07	06-Aug-07	06-Aug-07
2.1	Pour Slab	100%	07-Aug-07	07-Aug-07	07-Aug-07	07-Aug-07
3	Framing	20%	08-Aug-07	08-Aug-07	17-Aug-07	17-Aug-07
4	Structural Steel	0%	20-Aug-07	20-Aug-07	29-Aug-07	29-Aug-07

Figure 28 - Lot Status Report

Lot Closing Report



Lots Closing Report
13-Aug-07 to 31-Dec-07



Project: Hilltop Estates Stage 3
Phase: 1

Date: 12-Aug-07

Lot No	Days Remaining	% Complete	Closing Date	On Schedule
48	2	96%	14-Aug-07	Yes
52	19	66%	31-Aug-07	Yes
75	34	39%	15-Sep-07	NO
3	49	13%	30-Sep-07	NO
4	88	0%	08-Nov-07	-
18	120	0%	10-Dec-07	-
21	122	0%	12-Dec-07	-
65	125	0%	15-Dec-07	-

Figure 29 - Lot Closing Report

Daily Superintendant Schedule



Daily Superintendant Schedule
for 12-Aug-07



Project: Hilltop Estates Stage 3

Date: 12-Aug-07

Work Scheduled for Today

Lot No	Task	Company/ Trade	S	C	F	% to be Completed	Days before deadline
48	Inside Drains	Dranco			X	100%	1
	Basement Floor	Dranco	X	X	X	100%	1
	Garage Prep	Dranco	X	X	X	100%	1
78	Framing	Frameall		X		30%	10
	Garage Pour	Dranco	X	X	X	100%	1
115	Roof Shingles	Stephenson		X	X	100%	1
125	Form Footings	Basecrete	X	X	X	100%	1
	Pour Footings	Basecrete	X	X	X	100%	1
	Form Foundation	Basecrete	X			20%	3

S = Starting Today

C = Continuation (Work in Progress)

F = Finishing Today

Work to be Scheduled (to confirm with all Trades)

Lot No	Task	Company/ Trade	Scheduled Start Date
75	Drywall	Nelmar	13-Aug-07
	Kitchen & Vanity	Kitchenworks	15-Aug-07
	Garage Prep	Dranco	18-Aug-07
110	Framing	Frameall	18-Aug-07
	Garage Pour	Dranco	18-Aug-07
	Form Foundation	Basecrete	20-Aug-07

Figure 30 - Daily Superintendant Schedule

Completion Report



Completion Report

Lot 151



Project:	Hilltop Estates Stage 3	Buyer:	Mary Ryan	Date:	12-Aug-07
Phase:	1	Address:	48 Hilltop Drive	Closing Date:	15-Dec-07
Lot:	151	Elevation:	B		
Model:	Rose Hill (43-2)	Frontage:	15.0m		

Description	Trade	Status	Completion No	Estimated Date	Actual Date	Days Late
Foundation	Basecrete	Ready	C1451	03-Aug-07	03-Aug-07	0
Outside Sewers	Dranco	Ready	C1452	06-Aug-07	08-Aug-07	2
Inside Drains	Dranco	Pending	-	06-Aug-07		
Basement Slab	Dranco	Pending	-	07-Aug-07		
Framing	Frameall	Pending	-	17-Aug-07		
Structural Steel	Mansteel	Pending	-	29-Aug-07		

Figure 31 - Completion Report

Work Order Report



Work Order Report

All Lots



Project:	Hilltop Estates Stage 3	Date:	12-Aug-07
Phase:	1		

Lot No	Description	Trade	Status	Work Order No	Estimated Date	Actual Date	Days Late
1	Cold Cellar	Dranco	Ready	W2451	03-Aug-07	03-Aug-07	0
	3PC Rough-In	Dranco	Ready	W2452	06-Aug-07	08-Aug-07	2
3	Master Ensuite Upgrade	Plumbco	Pending	W2453	06-Aug-07		
	Rear Porch	Dranco	Pending	W2454	07-Aug-07		
78	Upgrade Brick to Stone	Brickit	Pending	W2455	17-Aug-07		
	Cold Cellar	Dranco	Pending	W2456	29-Aug-07		

Figure 32 - Work Order Report

Constructus
August 21, 2007

**Appendix C:
Signed Contract**

SYSTEM DEVELOPMENT AGREEMENT

This Agreement made the 21st day of August, 2007

B E T W E E N:

SENECA COLLEGE OF APPLIED ARTS

& TECHNOLOGY, an Ontario College having its
main campus at 1750 Finch Avenue East, Toronto,
Ontario M2J 2X5

(hereinafter "Seneca")

OF THE FIRST PART

- and -

Nino D'Aversa, Lukas Blakk, John Ford, Jesse Valianes
collectively students of Seneca, and having an address at 1750
Finch Avenue East, Toronto, Ontario M2J 2X5

(hereinafter collectively the "Students")

OF THE SECOND PART

- and -

TICE RIVER ESTATES INC.

1919 Albion Road
Etobicoke, Ontario
M9W 5S8

(hereinafter the "Customer")

OF THE THIRD PART

WHEREAS:

1. Seneca is in the business of educating students in a number of fields including computer software development;
2. The Students, as part of their course requirements to gain practical experience, are required to develop and install a computer software system for private businesses;
3. The Customer wishes to acquire a software system that will perform certain business functions;
4. Seneca is prepared to offer the services of the Students to develop a computer software system for the Customer to fulfill their course requirements;
5. This Agreement sets out the basis upon which Seneca, using the services of the Students, will develop the software system for the Customer.

NOW THEREFORE, in consideration of the premises and the covenants and agreements herein contained, the parties hereto covenant and agree as follows:

1. Schedules

The following are the schedules attached to and incorporated into this Agreement by reference:

Schedule A	Project Initiation Document
------------	-----------------------------

2. Definitions

In this Agreement, unless there is something in the subject matter or context inconsistent therewith, the expressions following shall have the meanings indicated below:

Acceptance Date:	The date on which the Software System successfully passes the Acceptance Test.
Acceptance Test:	The acceptance test applicable to the Software System and referred to in Paragraph 9 hereof.
Documentation:	All documentation regarding the Software System, including, but not limited to, online or hard copy instructions explaining how to use the Software System and how the overall system works,
Functional Specifications:	The description of the functions that the Software System is to perform, and the capabilities it is to have, as more particularly described in the Project Initiation Document

Hardware Platform:	The types and quantity of equipment referred to in the Project Initiation Document, which equipment will be used in conjunction with the Software System.
Software System:	A computer based program to perform the functions described in the Project Initiation Document, and to be developed, implemented, and installed by the Students.

3. Deliverables

The Students agree to develop the Software System in accordance with this Agreement, and to supply the following to the Customer:

- (a) the Software System and the source code version of any computer software, in machine - readable versions;
- (b) the Documentation;
- (c) the training described in Paragraph 10;
- (d) the software support described in Paragraph 11;

4. Price

The price for the development of the Software System and the provision of training by the Students shall be nil.

5. Implementation Plan

The development of the Software System shall be in accordance with the implementation plan in the Project Initiation Document. The Students and the Customer shall at all times use reasonable efforts to adhere to the schedule of events and timings therefore set forth therein, and no variation, modification, or amendment shall be made by one party without the prior written consent of the other party.

6. Development of the Software System

- (a) The Students shall develop the Software System in accordance with the Project Initiation Document, and shall prepare the Documentation.
- (b) The Customer shall use reasonable efforts to respond to requests for information reasonably required by the Students in connection with the development of the Software System.

7. Changes

Before the Acceptance Date of the Software System, the Students shall make any minor additions, modifications, changes, and enhancements to the Software System upon the written request of the Customer, at no charge, and shall modify the Documentation, as

necessary, to reflect the additions, modifications, changes, and enhancements made. Customer acknowledges that any major additions, modifications, changes and enhancements to the Software System are beyond the scope of this Agreement, and that neither Seneca nor the Students is obligated to provide and undertake the same.

8. Delivery and Installation

(a) After the Students have completed the development of the Software System, they shall deliver it to the Customer, together with the Documentation, and shall install it on the Hardware Platform.

(b) Installation of the Software System shall be deemed to be complete upon the Students certifying to the Customer that the Software System functions in accordance with the Functional Specifications.

9. Acceptance Test

After the Software System has been installed, it shall be subject to a series of acceptance tests (collectively the "Acceptance Test") using the relevant data, and shall be deemed to have passed such Acceptance Test upon the Customer being satisfied that it performs in accordance with the Functional Specifications, and fulfils the Customer's operational requirements. The Software System shall be considered to have successfully completed the Acceptance Test upon the Customer signing a written acknowledgment to that effect.

10. Education and Training

The Customer shall make available a sufficient number of its personnel to be trained for the various jobs concerning the operation and management of the Software System. All such personnel shall be reasonably capable of being trained for the jobs to which they are assigned. The Students agree to provide to the Customer all necessary education, training, and other assistance for the Customer's personnel to enable them to operate the Software System. The sessions at which such education and training are to be provided shall be scheduled at times and places mutually agreed to.

11. Software Support

During the period that the Customer is conducting the Acceptance Test, the Students shall provide to the Customer programming and system analysis services to correct any errors in the Software System that come to the attention of the Customer or the Students through any source. The Students shall use their best efforts to correct such errors promptly. The Customer shall cooperate with the Students by identifying the circumstances under which such errors were experienced. The Students shall notify the Customer promptly of the possible existence of such errors that come to their attention from sources other than the Customer. The Students

shall deliver to the Customer a revised copy of any computer software comprising the Software System, including the source code version thereof, and Documentation reflecting corrections made by them. Once the Acceptance Test has been completed, neither Seneca nor the Students shall be obligated to provide software support.

12. Ownership

(a) Unless otherwise specified in the Project Initiation Document, the Customer shall have all ownership rights, including trade secrets, copyright, and all other intellectual property rights, in the computer software and Documentation comprising the Software System.

(b) Where the Customer is the owner of the computer software and Documentation comprising the Software System under Paragraph 12(a), the Customer grants to the Students and to Seneca, and they accept from the Customer, a non-exclusivelicence to use the computer software and Documentation without restriction to the purposes for which they may subsequently intend. Without limiting the generality of the foregoing, Seneca shall have the right to use the computer software and Documentation for demonstration purposes to others, so long as it uses its own data in said demonstrations, or data approved by Customer with its express consent.

13. Conversion of The Customer's Files

The Students shall advise and consult with the Customer as to the alternative methods available for conversion of the Customer's files and creation of files for use with the Software System, but shall not be obligated to undertake the conversion or assist the Customer in same.

14. Confidential Information

Confidential Information shall mean all information relating to a party's business which is received by a party from the other party under this Agreement. The parties shall not make use of such Confidential Information other than for the performance of this Agreement, and shall not divulge or disclose the Confidential Information to any other person, corporation, association or otherwise, except to such employees of either party who may require such disclosure in order to fulfil the obligations of said party under this Agreement. The parties shall take reasonable precautions against the Confidential Information being used or acquired by any unauthorized person or persons, consisting of the same degree of care as each party uses in preserving the confidentiality of its own confidential information of a similar type. Excluded from this restriction is any Confidential Information which can be demonstrated to have been in the public domain prior to the date of its disclosure, or in the recipient party's possession prior to its receipt under this Agreement. The provisions of this Paragraph 14 shall survive expiration or termination of this Agreement or any licence created hereunder.

15. Limitation of Liability

Under no circumstances whatsoever shall Seneca or the Students be liable for any direct, indirect, special or consequential damages arising out of a breach of this Agreement, or the use of the Software System by the Customer.

16. Remedies of The Customer

- (a) In the event that the Students do not deliver the Software System by the due date therefore for causes not attributable to the Customer, the Customer may, at its option, terminate this Agreement with no further obligation or liability on the parties by written notice to the Students and Seneca, effective immediately.
- (b) In the event that the Acceptance Test cannot be completed successfully within the period prescribed therefore for causes attributable to the Students, the Customer at its option shall either (i) accept the Software System, at such level of performance, or (ii) terminate this Agreement by written notice to the Students and Seneca with no further obligation or liability on the parties, or (iii) permit the Acceptance Test to be continued for such period, not exceeding 10 days, as the Customer may designate by written notice. During such period of continuation of the Acceptance Test the Students shall make all necessary changes to any component of the Software System, and following such changes the Software System shall again be subjected to the Acceptance Test or any portion thereof not previously completed. In the event that following such changes the Acceptance Test cannot be completed successfully within a further period of 10 days from the commencement of same, the Customer may then at its option terminate this Agreement without further obligation or liability on the parties by written notice effective at any time, or restart the Acceptance Test.
- (c) In the event of termination of this Agreement pursuant to the provisions of this Paragraph 16, the Students shall deliver to the Customer the Software System in its then current state of development, the Documentation, working papers, computer files and output then in their possession and which are applicable to the Software System, at no further charge to the Customer, and return to the Customer all files and other materials belonging to the Customer.

17. Notices

Any notice, request, demand, consent or other communication provided or permitted hereunder shall be in writing and given by personal delivery, transmitted by e-mail or sent by ordinary mail, postage prepaid, addressed to the party for which it is intended at its address as set out on the first page of this Agreement, provided, however, that any party may change its address for purposes of receipt of any such communication by giving 10 days prior written notice of such change to the other party in the manner prescribed above. Any notice so given shall be deemed to have been received on the date on which it was delivered or transmitted by facsimile or any other electronic means of communication, or if mailed, on the fifth day next following the mailing thereof.

18. **Assignment**

This Agreement shall be binding upon and ensure to the benefit of the parties hereto and their respective successors and permitted assigns. No party shall assign this Agreement without first obtaining the written consent of the others.

19. **Entire Agreement**

This Agreement contains the entire agreement between the parties with respect to the subject matter thereof as of its date and supersedes all prior agreements, negotiations, representations and proposals, written and oral, relating to its subject matter.

20. **Governing Law**

This Agreement shall be governed by, subject to, and interpreted in accordance with the laws of the Province of Ontario.

IN WITNESS WHEREOF the parties hereto have executed this Agreement as of the date first written above.

SIGNED, SEALED & DELIVERED) Seneca College of Applied Arts & Technology
in the presence of)
)
) By: _____
)
) **Students**

)

) _____

)

)

) _____

)

) **Customer**

)

)

) By: _____

) SCHEDULE "A"

PROJECT INITIATION DOCUMENT

Date Submitted:	August 21, 2007
Team Number:	2
Team Members:	Nino D'Aversa, JohnFord, Jesse Valianes, Lukas Blakk
Project Title:	Constructus (Tice River Homes Tracking System)
Client Information:	Ray Di Donato President Tice River Homes 1919 Albion Road Etobicoke, Ontario M9W 5S8 416-675-2682
Target Completion Date:	April 30, 2008

Scope of System Being Developed

1. *Functions/features that the team will computerize for the client:*
 - *Tracking of work orders*
 - *Tracking of completions*
 - *Generate and print reports*
 - *Tracking lot status*
 - *Email notification of milestones*
 - *Scheduled backups of virtual machines*
 - *Tracking of contractors*
2. *Windows Server 2003 or 2007, Excel, Email programs, Blackberry, Postgres database*
3. *VM ware server installation, 6GB of hard disk space for base installation. No network setup is required since there is already a functioning network. Postgres install on one of the virtual machines.*

Use Case Grid

System Function	Use Case
Tracking of Work Orders	Manage Work Order
Tracking of Completions	Manage Completion
Generate and print reports	Manage Report
Tracking Lot Status	Manage Lot
Email Notification of Milestones	Email Notification
Tracking of contractors	Manage Contractor
Scheduled backups of virtual machines	Backup Virtual Machines

Constraints

Client uses Microsoft Excel for contract creation. Our system must be able to work with Excel. Windows platform is the current operating system so we will be limited to Windows Server 2003.

Risk Assessment and Planning

Postgres is the database we will be working with – our team will need to research and learn how to work with Postgres. Using virtual machines is unfamiliar territory to all but one team member. This will also involve a steep learning curve for our team. We will also be working with Java and all our team members have only had one course in this subject so our programming in Java will be tough at first. We feel that these risks are manageable and that they will not affect our delivery time.

Moral, Ethical and Legal Issues

A copy of the software must be made available to the team members using fictional data so that it may be used for portfolio demonstration purposes. We also will be using a BSD license for the system wherever possible because it allows us to sub-license to the client and server at no cost. The copyright for the software written by Team 2 will be shared equally by each team member and will be provided to Tice River through a BSD licensed binary and source components. Below is a template for the license to be used.

Copyright (c) 2007, Team 2

All rights reserved.

Redistribution and use in source and binary forms, with or without modification, are permitted provided that the following conditions are met:

- Redistributions of source code must retain the above copyright notice, this list of conditions and the following disclaimer.
- Redistributions in binary form must reproduce the above copyright notice, this list of conditions and the following disclaimer in the documentation and/or other materials provided with the distribution.
- Neither the name of the <ORGANIZATION> nor the names of its contributors may be used to endorse or promote products derived from this software without specific prior written permission.

THIS SOFTWARE IS PROVIDED BY THE COPYRIGHT HOLDERS AND CONTRIBUTORS "AS IS" AND ANY EXPRESS OR IMPLIED WARRANTIES, INCLUDING, BUT NOT LIMITED TO, THE IMPLIED WARRANTIES OF MERCHANTABILITY AND FITNESS FOR A PARTICULAR PURPOSE ARE DISCLAIMED. IN NO EVENT SHALL THE COPYRIGHT OWNER OR CONTRIBUTORS BE LIABLE FOR ANY DIRECT, INDIRECT, INCIDENTAL, SPECIAL, EXEMPLARY, OR CONSEQUENTIAL DAMAGES (INCLUDING, BUT NOT LIMITED TO, PROCUREMENT OF SUBSTITUTE GOODS OR SERVICES; LOSS OF USE, DATA, OR PROFITS; OR BUSINESS INTERRUPTION) HOWEVER CAUSED AND ON ANY THEORY OF LIABILITY, WHETHER IN CONTRACT, STRICT LIABILITY, OR TORT (INCLUDING NEGLIGENCE OR OTHERWISE) ARISING IN ANY WAY OUT OF THE USE OF THIS SOFTWARE, EVEN IF ADVISED OF THE POSSIBILITY OF SUCH DAMAGE.

Other Issues or Information

Signatures

Date